

# LGIP MT434 Genesis IP Masthead Receiver



2a Bellevue Road, Friern Barnet, London N11 3ER  
T. 020 8368 7887 F. 020 8368 3952  
info@luminite.co.uk

## Product Overview

Weather proof to IP66, the Genesis IP Masthead has all the features of the standard LGMT434 Masthead but with the addition of IP connectivity for Plug & Play alarm integrations and email system alerts.

IP connectivity enables local plug and play connectivity with selected Alarms, DVR's and NVR's as well as a host of remote monitoring software solutions. The IMMIX platform is one of the first to be integrated using the robust SMTP protocol. In addition to this another connection can be opened to provide client TCP/IP connection to the alarm system or DVR/NVR using a selectable protocol depending on the make or manufacture of the product. Panasonic

is one of the latest integrations which provides direct communication with up to three PTZ cameras per PIR.

The IP Masthead is future proofed by way of a 'Boot Loader' front end that allows remote upgrades of firmware as new releases become available. A new version of IP Configurator is available for download at the foot of this page. This FREE PC program enables the Masthead to be remotely configured for the appropriate alarm interface as well as installing Masthead firmware updates. A new feature enables up to three email addresses to be configured that will receive alerts such as 'low battery', 'missing call', 'tamper's & alarms'.



## Installation

IP interface is now possible using the new IP receiver and this allows all the previous types of interface with the addition of IP compatible products. The main feature is that a system can be remotely monitored by the installer to be informed of alerts such as low battery etc.

A powerful walk test instrument makes setting up the system easy and ensures that the installation is thoroughly tested and optimised.

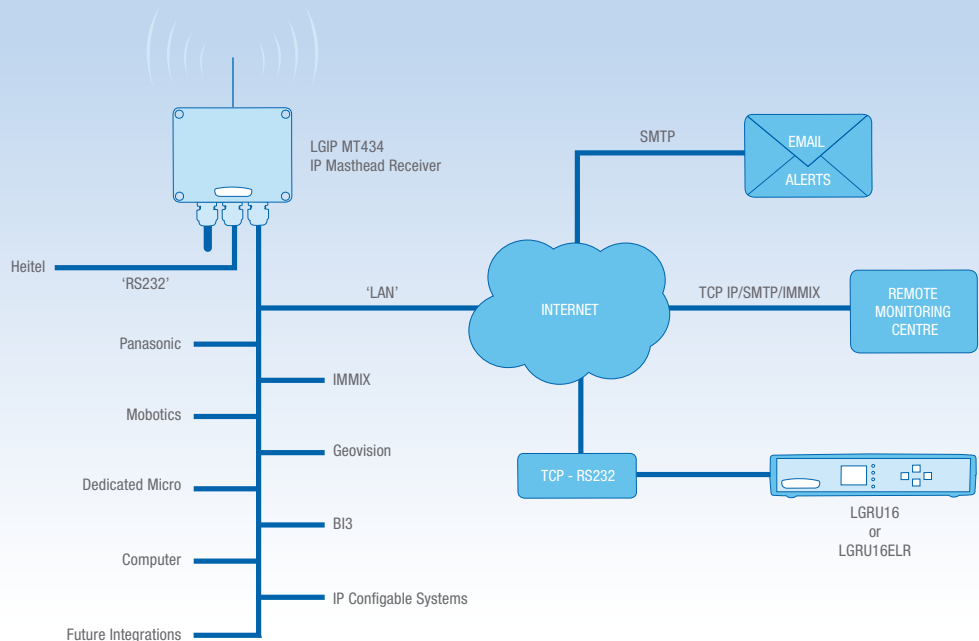

## For Use With LGIP MT434



Genesis LGWP  
Wireless PIR Detector



Genesis 2  
Wireless PIR Detector



LGTX434 Wireless  
Genesis Transmitter



LGRU16 Relay Unit  
16 Alarms & 16 Tamper



LGRU16ELR Relay Unit  
16 Alarms & 16 Tamper





LGWT434  
Walk Test Instrument

For more information see separate datasheets

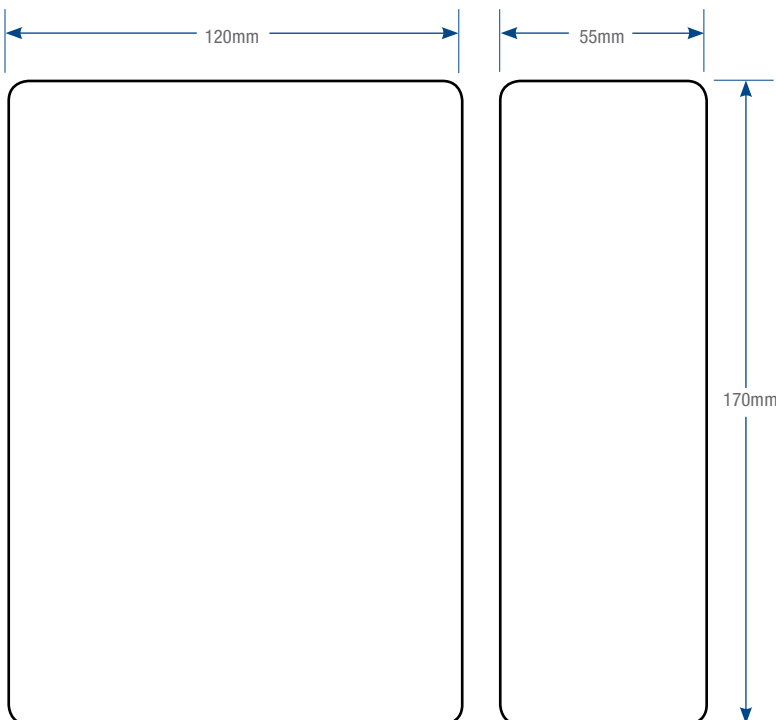
## Dimensions



## Specifications

|   |                                |
|---|--------------------------------|
| Receiver / Transmission Frequency   | 434.525Mhz                     |
| Reception / Transmission Range  | 1km line of sight (with AE434) |
| Aerial  | 50 ohm 1/4 wave                |
| Site codes  | 32                             |
| Unit codes  | 64                             |
| Output  | RS232 + Ethernet               |
| Operating voltage   | 9V DC                          |
| Protocol  | TCP IP                         |
| Power Consumption   | Max 170m/a                     |
| Temperature Range   | -10 deg C +60 deg C            |
| Weather Rating  | IP66                           |
| Enclosure   | ABS plastic housing            |
|    |                                |

