

**C106**  
**Coded Access Keypad**

Including:  
**CS106 and BL106**  
**Door Entry & Coded Entry**

PD-024 Issue 4



## Features

- Up to 10 codes each of 1 to 8 digits.
- Two Time Zones for Staff / Executive operation.
- Output for Fail-Safe and Fail-Secure locks.
- Exit button facility.
- Lock timer.
- Secure programming via the keypad.
- Non-volatile memory.

## Products

CS106 Series combined coded access and door entry system.

BL106 Series combined coded access and door entry system

## Contents

Features .....	3
Products .....	3
General Description.....	6
Basic Operation.....	6
Other Features: .....	6
Installation .....	9
Wiring for the C106 Keypad .....	9
Cable Requirements .....	10
Power Supply - Important Safety Information .....	11
Electric Lock Release .....	13
High Current Lock Releases .....	14
Time Restricted Access .....	15
Exit Button .....	15
Programming the C106 Keypad .....	16
General .....	16
Each program function is described in detail on the following pages. ....	16
Programming a New Access Code (Functions 1 to 10) .....	17
Changing the Security key (Function 91) .....	18
Programming the Action Codes (Functions 51 to 60) .....	20
Programming the Lock Duration (Function 95).....	22
Programming a Lock Delay Time (Function 96) .....	23
Programming the Factory Settings (Function 99).....	24
Summary of Program Functions.....	25
Table 1 - Programming Access Codes.....	25

## CS106/BL106 Combined Door Entry and Coded Access

---

Table 2 - Programming of Action Codes .....	26
Table 3 - Summary of Action Numbers .....	26
Table 4 - Programming of Other Functions.....	27
Commissioning .....	28
Testing the Lock Release Outputs.....	28
Testing the controller with factory settings .....	29
Troubleshooting .....	30
Programming the Factory Settings with the Test Button .....	32
Specification for the C106 Controller .....	33
CS106 / BL106 Combined Series .....	35
General Description.....	36
CS106 Complete Systems .....	36
BL106 Complete Systems.....	36
Installation of the Door Entry Phone System .....	37
Cable Planning .....	38
Cable Requirements .....	38
Installation Procedure .....	40
Troubleshooting .....	41
CS106-1/BL106-1 Wiring (1 Way Combined) .....	44
CS106-N/BL106-N Wiring (Multi-way Combined).....	45
Wiring Diagram - 2 Door System with the C106 .....	46

## **General Description**

The C106 Coded Access Controller is a high quality, versatile security product, controlling access to a door by means of a keypad and an electric lock release mechanism.

### **Basic Operation**

The C106 Keypad may be programmed with up to 10 unique access codes. If a valid code is entered on the keypad, the lock release will operate for a preset duration.

The keypad has one green and one red LED to indicate the system status to the user; the green LED indicates that the lock release is operating, whilst the red LED indicates an invalid entry.

### **Other Features:**

#### **Multiple codes**

The C106 has 10 access codes available each of which can be 1 to 8 digits long. The extra codes are provided for a variety of possible uses:-

- Multi-user applications, e.g. for a small office block.
- Time-restricted access (described below).

#### **Time-Restricted Access (Staff/Executive Operation)**

Any of the 10 access codes may be programmed to operate during a restricted

time period only. This time period can be determined by a time-clock or manually via a key switch.

For example, with factory settings, the operation of code 1 is unrestricted (Executive Code) whilst code 2 is restricted to when the time-clock input is closed (Zone 1 - Staff Code).

Codes can also be programmed to operate during alternate shifts. e.g. code 1 operates when the time-clock input is open (Zone 2) and code 2 operates when the time-clock input is closed (Zone 1).

Refer to 'Programming the Action Codes' page 20 and Table 1 page 25 for further details.

### **Exit Facility**

The Exit facility enables the lock release to be operated directly from a push-button for the predetermined lock duration. Typically this would be used to allow personnel to freely exit through the controlled door. The facility may also be used for a Fireman's' key-switch, or to interface with other security products such as a Door Entry Telephone System.

### **Lock Delay**

If required, the lock release can be programmed to operate after a preset time delay, following entry of the access code. This function is useful if the keypad is located a significant distance from the entrance.

### **Non-Volatile Memory**

The access codes and user programs are stored in a protected non-volatile EEPROM memory, which does not rely on batteries. The access codes and other programmable parameters are retained indefinitely without power

## **Programmable Options**

In addition to the 10 access codes the user may program the following other functions:

- ◆ Lock Duration (1-99 seconds)
  
- ◆ Lock Delay Time (0-99 seconds)
  
- ◆ Time-Restricted Access



## Installation

Read carefully all of the information presented in this chapter and then install the system in accordance with the wiring diagram below.

### Wiring for the C106 Keypad

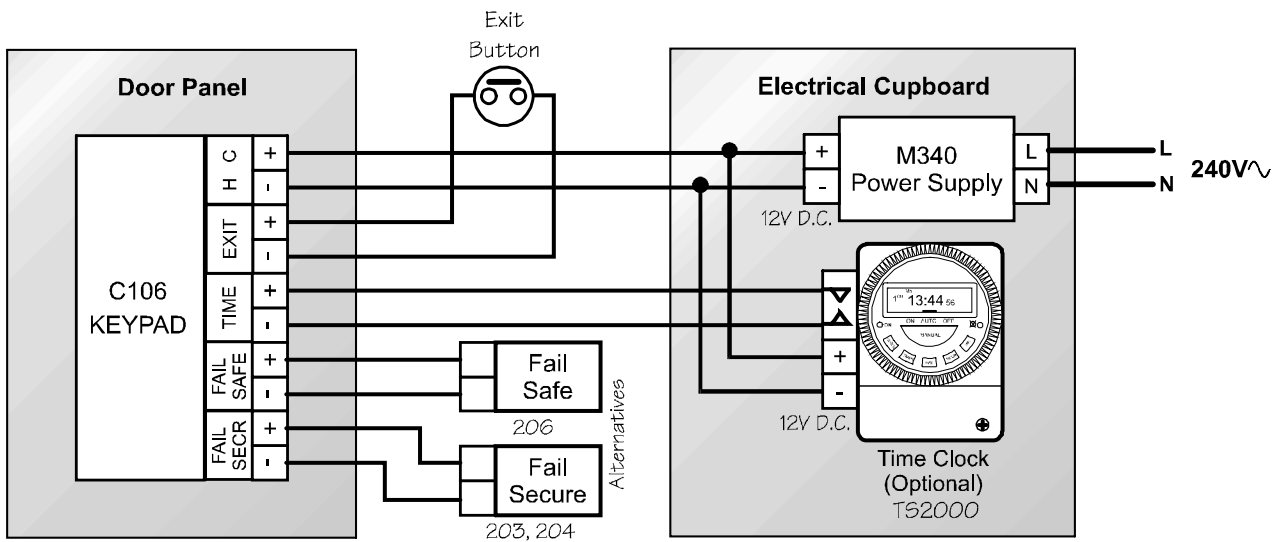

## Cable Requirements

### Cable Types

0.5mm:	Twisted pair, e.g. BT spec CW1308 or CAT5 UTP
1.0mm:	1.0mm <sup>2</sup> 'Twin mains flex'

Connections	No. of cores	Cable length	Core diameter
Power supply	2	up to 15M up to 50M	0.5mm 1.0mm
Lock release (up to 500mA)	2	up to 5M up to 25M	0.5mm 1.0mm
Time Clock	4	100M max.	0.5mm
Exit button	2	100M max.	0.5mm

In most cases cable length restrictions should not present a problem, however where longer lengths are required please refer to the manufacturer for advice.

## **Power Supply - Important Safety Information**

The Model 340C Power Supply must be wall mounted on to plasterboard, wood or a similar non-conductive material, in a protected indoor environment and close to a 240V AC electrical supply e.g. an electrical cupboard. Connections to the 240V AC mains supply must be carried out by a qualified electrician or similar competent person, and made in accordance with accepted safety practices.

A two pole switch (as provided by a Consumer Unit or Switch Fuse) must be included to isolate both Live and Neutral during Installation or Maintenance. The circuit must be protected by a fuse or other current limiting device, rated according to the capacity of the cable used, up to a maximum of 10A.

### **Fuse**

There is no serviceable fuse inside the model 340C Power Supply. It has an electronic current / thermal limit which will recover when a fault is removed.

### **Mains Cables**

Use only mains cable to BS6004, BS6500, or equivalent, within the following specified limits:

	<b>Minimum</b>	<b>Maximum</b>
Conductor Diameter	1.0mm (0.75mm <sup>2</sup> )	2.25mm (4mm <sup>2</sup> )
Cable Diameter	4.0mm	8.0mm

When fitting the cables (both primary and secondary) ensure that the cable entry cut-outs provided are used.

## Electric Lock Release

When installing lock releases please allow a little movement on the door as operation will be impaired if fitted too tightly.

The C106 Keypad provides two alternative pairs of connections for direct connection of an electric lock releases:-

**'FAIL SECR'**: Use these connections for 'Fail-Secure' lock releases. These devices require power to release the lock and will secure the door in the event of power failure. These are the most commonly used lock releases.

**'FAIL SAFE'**: Use these connections for 'Fail-Safe' lock releases and magnetic locks. Both of these devices require continuous power to lock the door and will release the door if power fails.

### Note

Any magnetic lock (Maglock) must be fitted with a suitable transient voltage suppressor, e.g. a diode or MOV. Please contact the manufacturer of the Maglock to check

These outputs are rated at the input voltage (12V  $\overline{=}$ ) with a maximum current consumption of 0.5A.

## High Current Lock Releases

For a lock release or a magnetic lock rated higher than 0.5A an additional power supply will be required. In addition a relay must be used to interface with the C106 Keypad.

The relay contacts, or the lock-release, must be fitted with a suitable suppression device to prevent voltage transient and electromagnetic interference being generated by the coil of the lock release. (Refer to manufacturer for further advice).

Consideration should be given to the problem of a voltage drop at the lock release. Please refer to the manufacturer of the particular lock release for information on suitable cable length versus thickness and power supply rating.

### High Current Lock Release

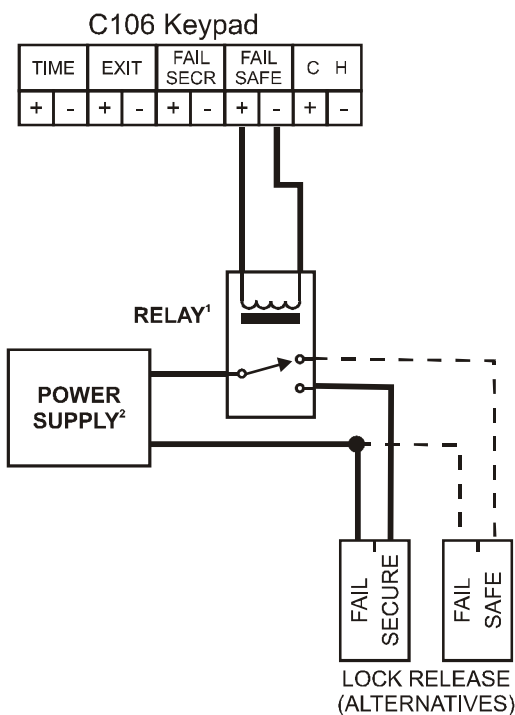

#### Notes:

1. Single-pole changeover relay, contact rating as per lock release. Lock release or contact must be suppressed for EMI.
2. Power Supply is AC or DC and rated according to lock release requirements. (polarity is not usually important)

#### Suitable Bell System Products

Product	Description	Fail Safe	Fail Secure
89	12V DC Relay, 10A Contact		
340C	12V DC Power Supply	1.5A	
PS4	12V DC Power Supply	3A	4A
225	12V AC Power Supply	2A	

## Time Restricted Access

The C105 Keypad has a pair of terminals marked 'TIME' which can be connected to an external Time Clock or Key switch to control time-restricted access. Any switch contact must be fully isolated (i.e. voltage free), the TS2000-BST Time Clock is normally used.

Access codes may be programmed as follows:

Access	Time Switch Status	Usage
No Restriction	-	Executive
Zone 1	Contact Closed	Staff (shift 1)
Zone 2	Contact Open	Staff (shift 2)

## Exit Button

The terminal marked 'EXIT' may be connected to an external push-button (e.g. 5077 switch) for 'push to exit' operation. Momentarily operating this button will directly operate the lock release for the programmed duration.

Alternatively, the input may be used with a Fireman's Override key-switch, which should be of the normally-open type. If this feature is to be used it is important that the lock release be of a continuously-rated design.

In general, a switch connected to the 'EXIT' terminals should be fully isolated i.e. Voltage-free.

## Programming the C106 Keypad

### General

The 10 access codes, lock time etc, are all programmed via the keypad. To prevent unauthorised use, a security key (1 - 8 digits) must be entered.

The basic principle of programming is as follows:

#### Procedure

- Enter the security key (1 to 8 digit number, default 1212). Check the red LED flashes continuously.
- Enter a key sequence on the keypad.
- Observe both the red and green LEDs flash for one second.
- When all functions are programmed, exit program mode by pressing **\*\***. The red LED stops

Each program function is described in detail on the following pages.



## Programming a New Access Code (Functions 1 to 10)

The C106 Keypad has ten access codes. Each code may be between 1 to 8 digits long.

### Procedure

- ◆ Enter the current Security key (default 1212). Check the red LED flashes continuously.
- ◆ Type :  
**< 1 - 10 > \* <New Code> #**
- ◆ Both LEDs flash once
- ◆ Exit program mode by pressing **\*\***

### Example

**1 \* 7754 #**

(code 1 = 7754)

**5 \* 8652 #**

(code 5 = 8652)

### NOTE

By default code 2 will only work when the TIME terminals are shorted and codes 3 to 10 are disabled. The Action codes should be adjusted as required, refer to page 20

## Changing the Security key (Function 91)

The security key is the code that must be entered on the keypad to gain access to the settings.

The security key is factory set to **1212**, to maintain security we recommend that this be changed immediately.

To ensure an adequate level of security it is recommended that a minimum of 4 digits be used for the security key, giving 10,000 combinations.

### Procedure

- ◆ Enter the current Security key.
- ◆ Type :  
**91 \* <New Key> #**
- ◆ Both LEDs flash once
- ◆ Exit program mode by pressing \*\*

### Example

**91 \* 87305 #**

(Security key = 87305)

Factory Setting = 1212

### **Choosing an access code**

To ensure an adequate level of security it is recommended that a minimum of 4 digits be used for each access code, giving 10,000 combinations. Codes should be chosen carefully to avoid obvious sequences and repetitions (e.g. 12345, 258, and 4444) which may be easily guessed or discovered. Try to choose codes with a random appearance (e.g. 6149, 186403) and avoid telephone numbers and other meaningful codes which, again, may be guessed by a would-be intruder. It is also a good idea to regularly change the access codes.

When choosing access codes it is important that no code is a subset of another code, e.g. If code 1 = 234 and the code 2 = 12345, code 2 would never open the door as 234 is a subset of 12345.

### **Maintenance**

It is important also that the keypad be regularly cleaned to remove finger marks which may give clues as to the access code. Use a soft cloth moistened with dilute detergent. Do not use organic solvents or any other cleaner.

## Programming the Action Codes (Functions 51 to 60)

Each access code has an associated action number. This is a single digit from 0-3 which determines the action that occurs following the entry of that access code.

Function 51 - Code 1 action code.

Function 52 - Code 2 action code.

.

.

.

Function 60 - Code 10 action code.

### Summary of Action Codes

Code	Action
0	No action ( code is disabled)
1	Lock operates
2	Lock operates only if Time contacts are closed (Zone 1)
3	Lock operates only if Time contacts are open (Zone 2)

**Procedure**

◆ Enter the current Security key (default 1212).

◆ Type :

**<51 – 60> \* <Action No> #**

◆ Both LEDs flash once

◆ Exit program mode by pressing \*\*

**Example**

**52 \* 1 #**

Code 2: Action No.=1  
(Operate lock always)

No	Function	Key Sequence	Factory Setting
51	Code 1 Action Number	<b>51 * &lt;0-3&gt; #</b>	1 (Operate always)
52	Code 2 Action Number	<b>52 * &lt;0-3&gt; #</b>	2 (Zone 1 - Operate when Time closed)
53 - 60	Code 3 to Code 10 Action Number	<b>53 - 60 * &lt;0-3&gt; #</b>	0 (Disabled)

## Programming the Lock Duration (Function 95)

This is the duration the lock release will operate for when triggered by an access code or by the 'EXIT' input. It is programmable in the range 1-99 seconds.

### Procedure

- ◆ Enter the current Security key (default 1212).
- ◆ Type :  
**95 \* <1-99> #**
- ◆ Both LEDs flash once
- ◆ Exit program mode by pressing \*\*

### Example

**95 \* 7 #**

(7 seconds)

**95 \* 12 #**

(12 seconds)

Factory Setting = 3 seconds

## Programming a Lock Delay Time (Function 96)

This function causes a delay (0-99 seconds) to be introduced between the triggering of the lock release and its operation. Typically, this facility is used when the keypad is located some distance from the entrance.

### Procedure

- ◆ Enter the current Security key (default 1212).
- ◆ Type :  
**96 \* <0-99> #**
- ◆ Both LEDs flash once
- ◆ Exit program mode by pressing \*\*

### Example

**96 \* 3 #**

(3 second delay)

Factory Setting = 0 seconds

## Programming the Factory Settings (Function 99)

In the event of any problems, always return to Factory settings.

### Procedure

- ◆ Enter the Security key.
- ◆ Type : **99 \* #**
- ◆ Both LEDs flash once
- ◆ Exit program mode by pressing **\*\***

If you have forgotten the Security key see 'Programming the Factory Defaults Using the Test Button' page 32

No	Function	Factory Setting
1	Program Code 1	1 2 3 4 5
2	Program Code 2	6 7 8 9 0
3 - 10	Program Codes 3 to 10	Disabled
51	Code 1 Action Number	1 (Operate always)
52	Code 2 Action Number	2 (Operate when Time closed)
53 - 60	Code 3 to 10 Action Numbers	0 (Disabled)
91	Security key	1 2 1 2
95	Lock Duration	3 seconds
96	Lock Delay	0 (Disabled)



## Summary of Program Functions

**Table 1 - Programming Access Codes**

No.	Function	Key sequence	Factory Setting
1	Program Code 1	<b>1 * &lt;1-8 digits&gt; #</b>	1 2 3 4 5
2	Program Code 2	<b>2 * &lt;1-8 digits&gt; #</b>	6 7 8 9 0
3	Program Code 3	<b>3 * &lt;1-8 digits&gt; #</b>	Disabled
4	Program Code 4	<b>4 * &lt;1-8 digits&gt; #</b>	Disabled
5	Program Code 5	<b>5 * &lt;1-8 digits&gt; #</b>	Disabled
6	Program Code 6	<b>6 * &lt;1-8 digits&gt; #</b>	Disabled
7	Program Code 7	<b>7 * &lt;1-8 digits&gt; #</b>	Disabled
8	Program Code 8	<b>8 * &lt;1-8 digits&gt; #</b>	Disabled
9	Program Code 9	<b>9 * &lt;1-8 digits&gt; #</b>	Disabled
10	Program Code 10	<b>10 * &lt;1-8 digits&gt; #</b>	Disabled

**Table 2 - Programming of Action Codes**

No	Function	Key Sequence	Factory Setting
51	Code 1 Action Number	<b>51 * &lt;0-3&gt; #</b>	1 (Operate always)
52	Code 2 Action Number	<b>52 * &lt;0-3&gt; #</b>	2 (Operate when Time closed)
53	Code 3 Action Number	<b>53 * &lt;0-3&gt; #</b>	0 (Disabled)
54	Code 4 Action Number	<b>54 * &lt;0-3&gt; #</b>	0 (Disabled)
55	Code 5 Action Number	<b>55 * &lt;0-3&gt; #</b>	0 (Disabled)
56	Code 6 Action Number	<b>56 * &lt;0-3&gt; #</b>	0 (Disabled)
57	Code 7 Action Number	<b>57 * &lt;0-3&gt; #</b>	0 (Disabled)
58	Code 8 Action Number	<b>58 * &lt;0-3&gt; #</b>	0 (Disabled)
59	Code 9 Action Number	<b>59 * &lt;0-3&gt; #</b>	0 (Disabled)
60	Code 10 Action Number	<b>60 * &lt;0-3&gt; #</b>	0 (Disabled)

**Table 3 - Summary of Action Numbers**

Code	Action
0	No action ( code is disabled)
1	Lock operates
2	Lock operates only if Time contacts are closed (Zone 1)
3	Lock operates only if Time contacts are open (Zone 2)

**Table 4 - Programming of Other Functions**

No	Function	Key Sequence	Factory Setting
91	Security key	<b>91 * &lt;1-8 digits&gt; #</b>	1 2 12
95	Lock Duration	<b>95 * &lt;1-99 secs&gt; #</b>	3 seconds
96	Lock Delay	<b>96 * &lt;0-99 secs&gt; #</b>	0 (Disabled)
99	Program Factory Settings	<b>99 * #</b>	

## Commissioning

After installation of the C106 unit, follow the two test procedures below; any problems can be diagnosed from the troubleshooting section. Finally program the required security and access codes (page 16).

### Testing the Lock Release Outputs

Ensure that the lock release is connected to the correct output (as shown in the Wiring diagram on page 9).

**Press and hold the C106 Keypad TEST button:**

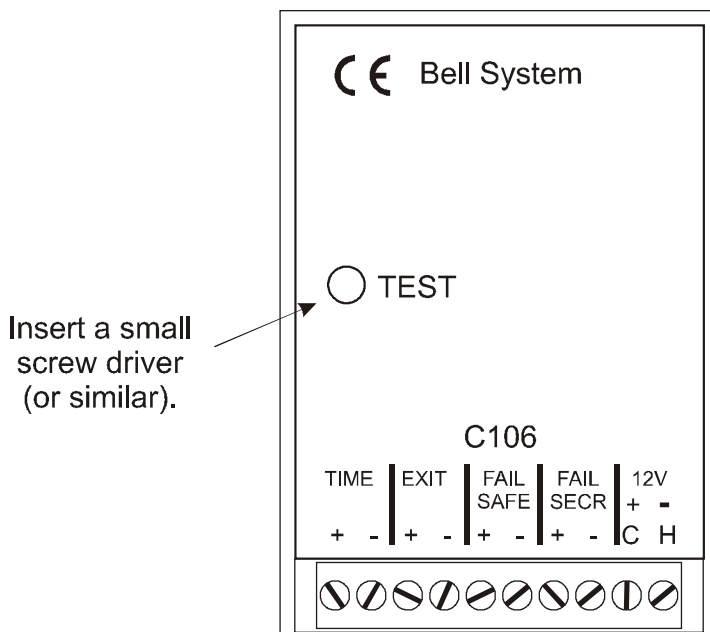

- Both of the Lock Outputs (Fail-Safe and Fail-Secure) and both red and green LEDs will illuminate.
- After 5 seconds the LEDs will start to alternate and the lock output will stop operating; you should release the test button at this stage to avoid programming the factory settings (see page 32).

## Testing the controller with factory settings

Before proceeding with this test ensure that the lock release is working correctly by following the tests on page 28.

Program to factory settings by following the instructions on page 24 or 32.

- ◆ Type in code 1 (**1 2 3 4 5**) - this should operate the lock release for 3 seconds.
- ◆ If a time clock is present on the system, manually switch it to OFF and type code 2 (**6 7 8 9 0**), nothing should happen. Now manually switch the time clock to ON and retype code 2 (**6 7 8 9 0**) - the lock release should operate for 3 seconds.
- ◆ Reprogram code 1 to another value by following the instructions under the heading 'Programming a new access code' (page 17); check that the new code operates the lock release and that the old one does not.
- ◆ If everything is functioning correctly, reprogram the security key (factory set to **1212**), to maintain security.
- ◆ Reprogram access codes, action codes and other parameters as required (pages 16 to 24).

## Troubleshooting

Use the table below to determine the most probable cause of a fault condition.

Symptom	Possible Cause/Remedy
When power applied nothing happens (LEDs do not flash)	<ul style="list-style-type: none"> <li>● Power Supply is overloaded. Remove externally connected components until the fault disappears.</li> <li>● Polarity not correct. Measure the voltage at the C106 (+ , -)</li> <li>● Check Power Supply Fuses. Always replace with fuses of the correct type and rating.</li> </ul>
Lock release operates in reverse	<ul style="list-style-type: none"> <li>● Incorrect output has been used; Transpose connections between Fail-safe and Fail-secure outputs.</li> </ul>
Red and Green LEDs flash together when attempting to operate lock-release.	<ul style="list-style-type: none"> <li>● Fail-secure Lock release output is short-circuited or of an incorrect rating; temporarily disconnect the lock release and retry (Green LED on for 3 seconds), test lock release (page 28)</li> </ul>
The lock release fails to operate when the Test button is pressed	<ul style="list-style-type: none"> <li>● Check the lock release and its wiring by moving the lock connections to + C, -H, (forcing the lock)</li> <li>● Measure the voltage on the FAIL SECR terminals; this should be the same as the power supply (13.8V) while the test</li> </ul>

Symptom	Possible Cause/Remedy
	button is pressed.
Lock release does not operate when Exit Button is pressed.	<ul style="list-style-type: none"> <li>● Test by applying a short-circuit directly to the 'EXIT' terminals; Check connections to Exit button.</li> </ul>
Lock operates from the test button but does not operate when the code is entered.	<ul style="list-style-type: none"> <li>● Check C106 Keypad is correctly programmed; Restore to Factory Settings (page 24, 32);</li> <li>● Time Clock in wrong state; reprogram action code, manually switch the time clock.</li> </ul>
Lock release is permanently active	<ul style="list-style-type: none"> <li>● 'EXIT' terminals are short-circuited; temporarily remove connections to 'EXIT' and re-test unit. Check any exit button connected to the EXIT terminals is 'push to make' and not the opposite</li> </ul>
Can't change any of the settings. Green LED is on	<ul style="list-style-type: none"> <li>● 'EXIT' terminals are short-circuited; temporarily remove connections to 'EXIT' and re-test unit. Check any exit button connected to the EXIT terminals is 'push to make' and not the opposite</li> </ul>

## Programming the Factory Settings with the Test Button

In the event of any problems, always return to Factory Settings. If the security key has been forgotten, the test button can be used to restore factory settings. In the case of a fault disconnect the lock release, before following this procedure.

This operation will restore all codes, times and functions to the factory settings (see Table 1 page 25 for the complete list).

This facility is useful for fault diagnosis. It makes use of the Test Button on the C106 Keypad. It is always advisable to return to this condition whenever the unit appears to malfunction during installation or following an unsuccessful programming session.

### To program Factory Settings

- ◆ Press and hold the TEST button.
- ◆ Observe the red and green LEDs come on (5 seconds)
- ◆ Observe the red and green LEDs alternating (3 seconds)
- ◆ Finally the red and green LEDs will flash together for 1 seconds and extinguish. The Factory Settings are now restored; release the TEST button.

Insert a small screw driver (or similar).

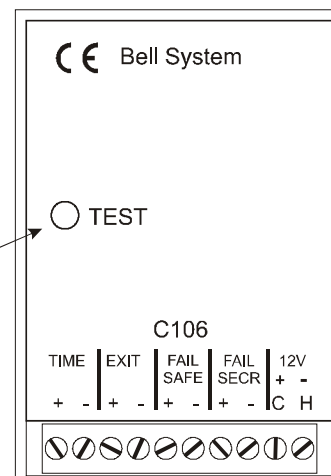



## Specification for the C106 Controller

### Lock

Output Voltage:	Same as Input Voltage
Load (maximum):	0.5A (load inductive or resistive)

Note : Inductive loads such as Maglocks must have suitable transient voltage suppression fitted, e.g. a diode or MOV

### Power (C + & H -)

Input Voltage:	12V to 14V $\overline{=}$
Current (maximum):	60mA

### Dimensions

C106 Keypad:	90mm x 62mm x 33mm
Panel Cut-out:	87.75mm x 59.7mm
Panel Thickness	2mm or 3mm



**CS106 / BL106 Combined Series**  
**Combined Door Entry and Coded Access Keypad**

## General Description

The CS106 / BL106 series systems are combined Door Entry Telephone and Coded Access Systems. The entrance panel incorporates a number of push buttons for each telephone, a speaker grill and an integral C106 keypad.

## CS106 Complete Systems

The CS106-N systems include all of the components necessary for a single-door Coded Access and Door Entry Telephone System:-

- 1 C106 Coded Access Keypad.
- 1 CP106-N Anodised Aluminium Entrance Panel with integral keypad and surface mounting back-box and including a model 61 speech unit.
- N* 801 Door Entry Telephones
- 1 203 Surface fitting, Fail secure, Lock Release.
- 1 340C Power Supply Unit

## BL106 Complete Systems

The BL106-N systems use the Bellini style Aluminium Entrance Panel with integral C106 keypad and are surface fitting only and include the model 61 speech unit. 801 Door entry telephones and a 340C power supply are also included. No lock release is included.

*N* - specifies the number of push-buttons/telephones (e.g. CS106-3: 3 phone system)

## **Installation of the Door Entry Phone System**

From an electrical point of view, the combined systems may be regarded as separate door entry and coded access systems with the exception of a common lock release. The coded access system and its installation are described in detail in the preceding half of this manual. The wiring diagrams on pages 44 and 45 show the wiring connections for the Door Entry Telephone System, including the simple connections which interface with the C106 Coded Access Controller.

### **The Model 801 Door Entry Telephone**

This is designed to be wall mounted in a convenient indoor location.

### **The Entrance Panel**

It should be mounted on an outside wall near the front door, and in a sheltered location. There is an option for CS106 systems to have a flush entrance panel.

### **Extension Phones**

Each apartment can have up to 3 extension phones (4 phones in total).

### **Tradesman button (optional)**

This is used in conjunction with a time-clock (e.g. TS2000-BST) to allow tradesmen access during restricted hours. The time-clock may be 240V AC or 12V DC operated, but must have a voltage-free isolated contact.

# Cable Planning

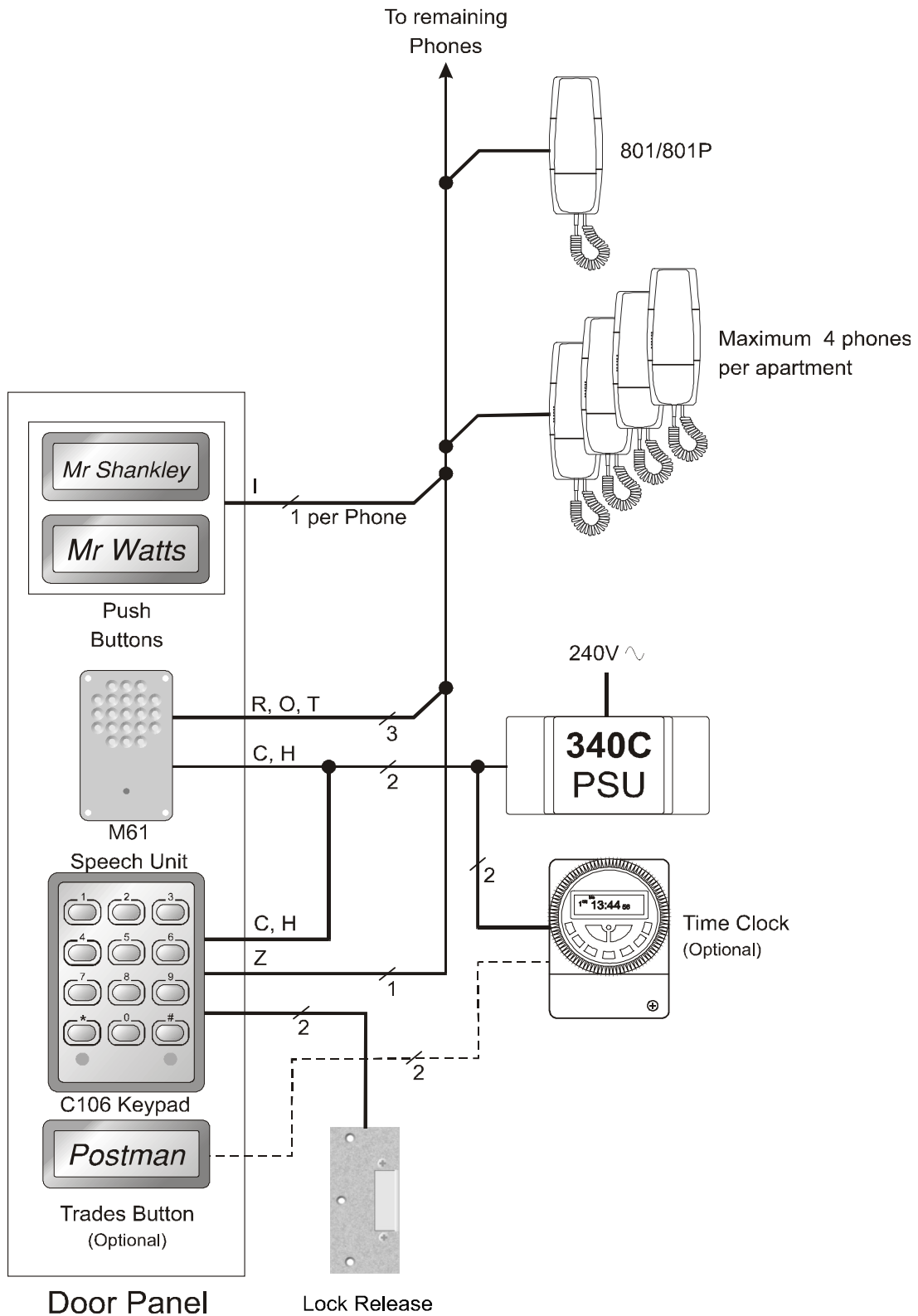

## Cable Requirements

## CS106/BL106 Combined Door Entry and Coded Access

---

For optimum clarity of speech it is strongly recommended that this system is installed using twisted-pair telephone cable (e.g. type CW1308). Use one of the pairs for the R & O connection between the speech unit and the telephone.

<b>Connections</b>	<b>No. of cores</b>	<b>Core diameter</b>	<b>Cable length</b>
Phone	4 + 1 per phone	0.5mm	100M max.
Power Supply	2	0.5mm	up to 15M
		1.0mm	up to 50M
Lock release (up to 500mA)	2	0.5mm	up to 5M
		1.0mm	up to 25M
Time clock	4	0.5mm	100M max.
Exit	2	0.5mm	100M max.
Trades Button	2	0.5mm	100M max.

In most cases cable length restrictions should not present a problem, however where longer lengths are required please refer to the manufacturer for advice.

## **Installation Procedure**

Connect all items by following the wiring diagram, on page 44 or 45. It is strongly recommended that a single telephone be connected at a time and fully tested before proceeding to the next.

### **Speech adjustment**

The model 61 speech units have two pots at the rear for adjustment of speech levels as follows:

Volume A:       Speech level at the Entrance Panel

Volume B:       Speech level at the Telephone



## Troubleshooting

Use the table below to determine the most probable cause of a fault condition. Refer also to page 28 for problems with the coded access system (C106 Keypad).

### Telephone Problems

Symptom	Possible Cause/Remedy
Low Speech Volume	<ul style="list-style-type: none"> <li>● Volume adjustment required on speech unit.</li> <li>● Speech unit is not tight against the panel grill.</li> <li>● Panel grill is blocked</li> <li>● More than one telephone is off the hook.</li> <li>● Speech unit supply voltage is low. Check 10V - 15V across 'C' and 'H'.</li> </ul>

Symptom	Possible Cause/Remedy
<p>Constant tone/feedback when in use.</p>	<ul style="list-style-type: none"> <li>● Volume adjustment required on the Speech Unit.</li> <li>● Speech Unit is not tight against the panel grill.</li> <li>● 'O' connection between Speech unit and telephone is open circuit.</li> <li>● Entrance panel and telephone are too close together.</li> <li>● The entrance panel is surrounded by reflecting walls.</li> <li>● Panel grill is blocked.</li> </ul>
<p>No speech when the phone is buzzed</p>	<ul style="list-style-type: none"> <li>● Wiring fault on the speech signal connections 'R' or 'T': 'R' carries the phone microphone signal to the speech unit; 'T' carries the Speech unit microphone to the phone.</li> </ul>

### Miscellaneous Problems

Symptom	Possible Cause/Remedy
Telephone will not buzz.	<ul style="list-style-type: none"> <li>Faulty 'O' or 'I' line between power supply and phone. Check 10.5V - 15V across 'I' and 'O' when called.</li> </ul>
Telephone 'DOOR' button does not operate release; C106 test button does operate the lock	<ul style="list-style-type: none"> <li>Missing connection to C106 Keypad Exit + terminal.</li> <li>Fault on 'Z' or 'O' line.</li> </ul>
Trades, Exit button or Fire Switch inoperative.	<ul style="list-style-type: none"> <li>Time-Clock is not running or incorrectly set (Trades button only).</li> <li>Check all connections to the EXIT terminal on the C106.</li> </ul>

## CS106-1/BL106-1 Wiring (1 Way Combined)

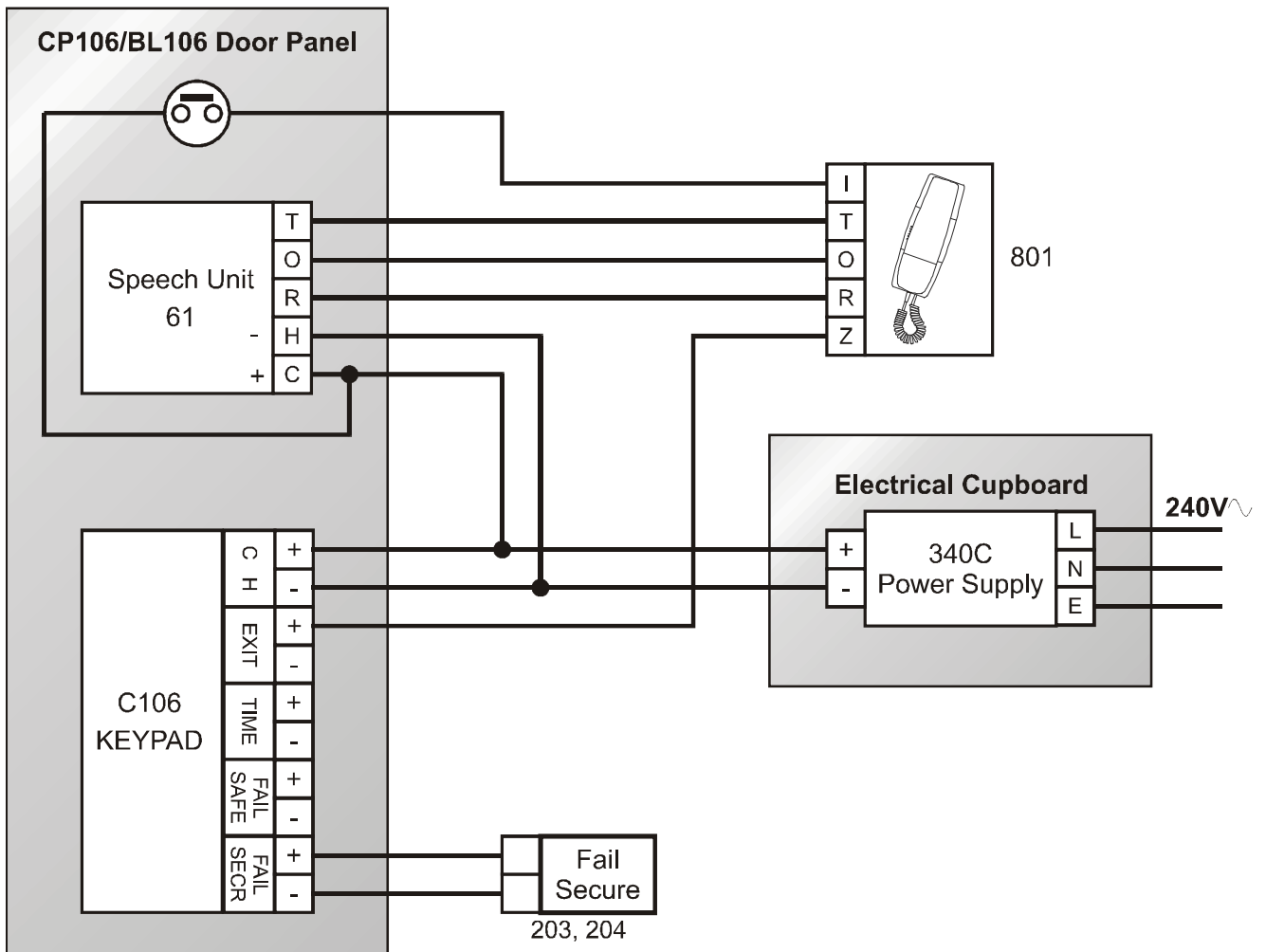

# CS106-N/BL106-N Wiring (Multi-way Combined)

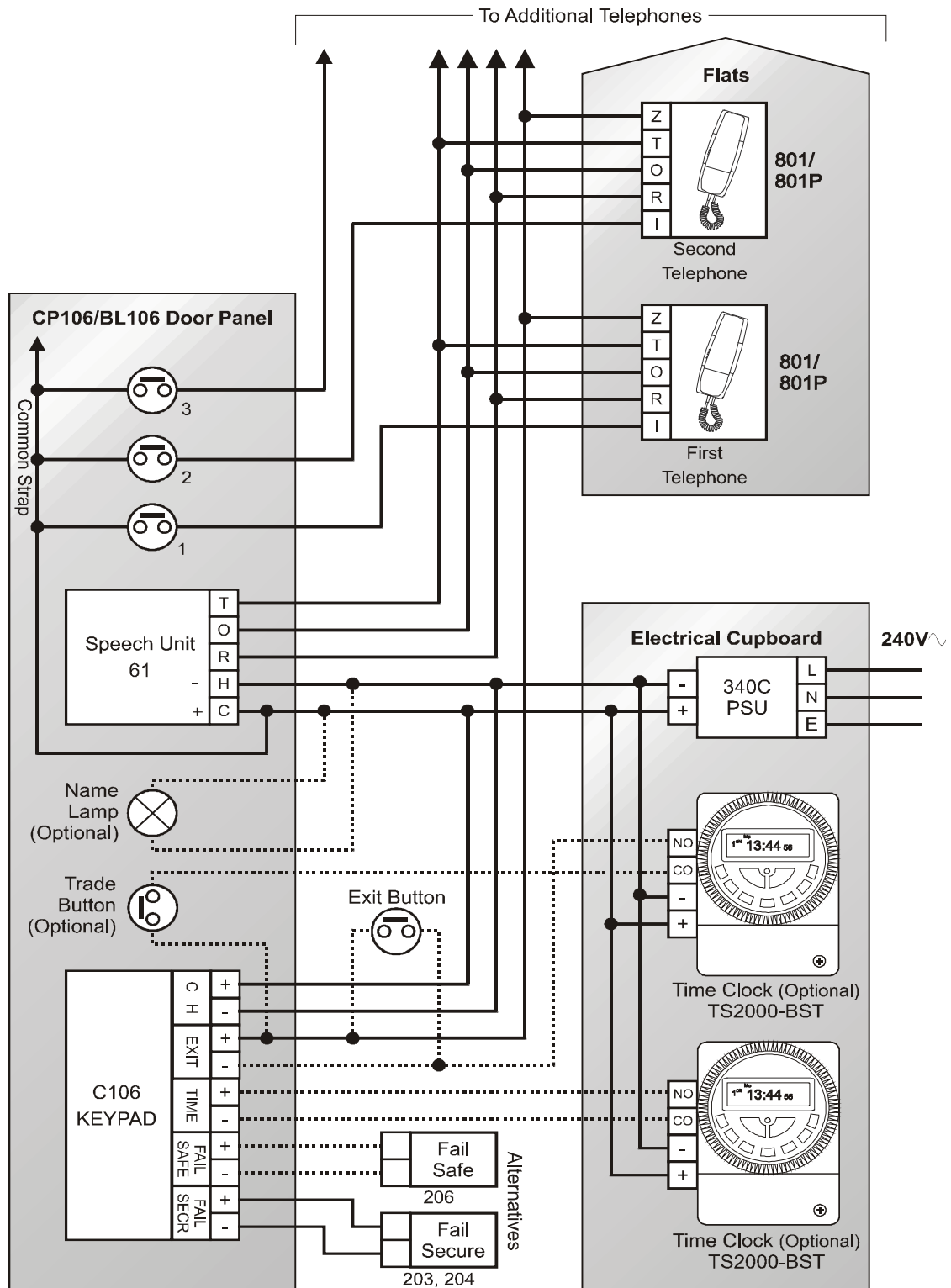

# Wiring Diagram - 2 Door System with the C106

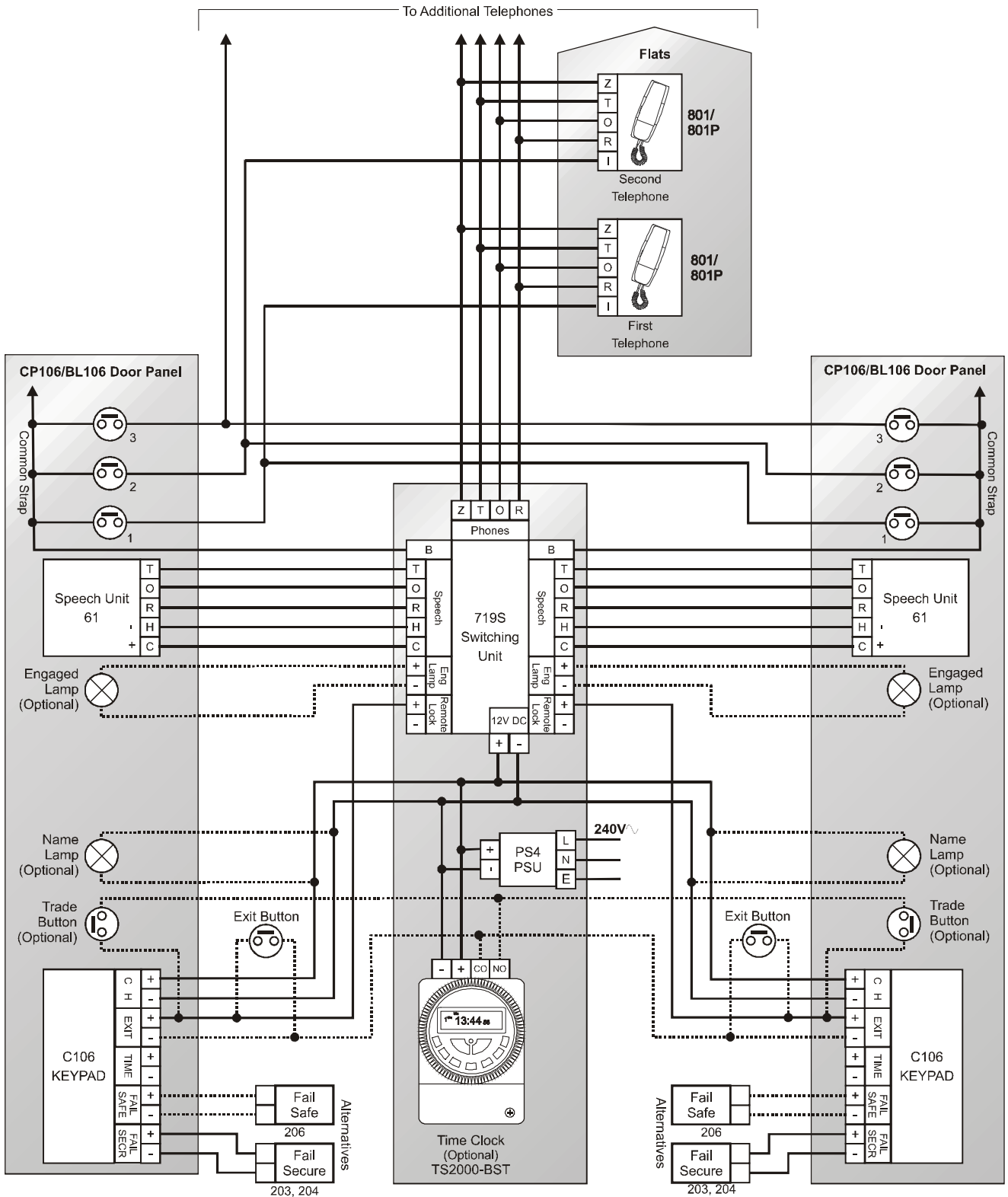



## Bell System (Telephones) Ltd.

Presley Way,  
Crown Hill,  
Milton Keynes  
MK8 0ET.

Tel: 01908 261106 (Sales and Technical Support)  
FAX: 01908 261116

OR

Local rate numbers

Tel: 0845 121 4008 (Sales and Technical Support)  
FAX: 0845 121 4009

E-mail: sales@bellsystem.co.uk  
technical@bellsystem.co.uk

Website: [www.bellsystem.co.uk](http://www.bellsystem.co.uk)

## Standards

This product complies with Electromagnetic Compatibility directive  
2004/108/EC and Low Voltage directive 2006/95/EC.

Emissions: Generic BSEN 61000-6-3

Immunity: Generic BSEN 61000-6-1

Low Voltage: Generic BSEN 60950

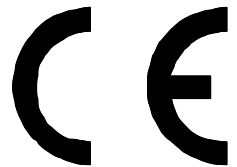

**bell**  
**system**  
(Telephones) Ltd

