

TIMEGUARD®

360° Surface Mount Ceiling PIR Light Controller

Model: SLW360L



Installation & Operating Instructions

1. General Information

These instructions should be read carefully and retained for further reference and maintenance.

2. Safety

- Before installation or maintenance, ensure the mains supply to the PIR sensor is switched off and the circuit supply fuses are removed or the circuit breaker turned off.
- It is recommended that a qualified electrician is consulted or used for the installation of this PIR sensor and install in accordance with the current IEE wiring and Building Regulations.
- Check that the total load on the circuit including when this PIR sensor is fitted does not exceed the rating of the circuit cable, fuse or circuit breaker.

3. Technical Specifications

- 230V AC 50 Hz
- Motion Detection Range: Up to 6 metres diameter (3m Radius) at a 2.5m mounting height
- This PIR sensor is of class II construction and must not be earthed
- Detection Angle: 360°
- Maximum Switching Load; 2400W Halogen, 500W Fluorescent, 150W CFL/Low Energy, LED lamps <10W Lamps, max 100W. LED lamps >10W <32W, max 50W. 75W Fan
- Time ON Adjustment: 5 seconds to 18 minutes.
- Dusk Level Adjustment: Day and Night or Night time only operation.
- IP44 Rated suitable for restricted internal applications
- CE Approved
- Manual Override
- Multiple PIR Sensor Switching: A maximum of 8 SLFM360L PIR sensors can be wired in parallel, to enable any detector to turn ON all the lights connected. The total load must not exceed the lamp rating of a single SLFM360L unit.

4. Selecting a Location

- The motion detector has number of detection zones, at various vertical and horizontal angles as shown (See diagram "A").
- The best all-round coverage is achieved with the unit mounted at the optimum height of 2.5 metres.
- Careful positioning of the sensor will be required to ensure optimum performance (see diagram "A" & "B" detailing detection range and direction).
- The sensor is more sensitive to movement ACROSS its field of vision than to movement directly TOWARDS (See diagram "B"). Therefore position the unit so that the sensor looks ACROSS the likely approach path.
- Avoid positioning the sensor where there are any sources of heat in the detection area (extractor fans, tumble dryer exhausts etc.) including opposite any other light sources such as other security lights.
- Reflective surfaces (i.e. pools of water or white painted walls) may cause false activation under extreme conditions.

2

Diagram A

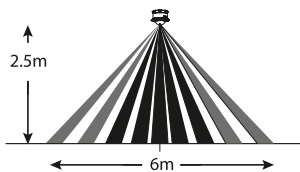

Top View

360°

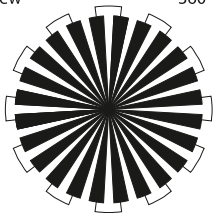
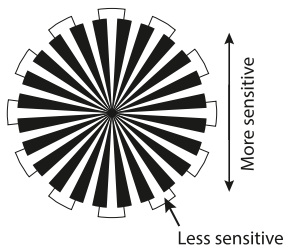

Diagram B



5. Installation & Connection

- Ensure the mains supply is switched off and the circuit supply fuses are removed or the circuit breaker turned off.
- An isolating switch should be installed to enable the power to be switched ON & OFF for maintenance purposes and to activate the manual/auto override function.
- Remove the top cover of the sensor by twisting the top cover anti-clockwise until the arrows (See diagram "E") are aligned. The top cover can now be removed from the sensor body.
- Mark the position of the mounting holes (See diagram "D"). Drill out the mounting holes taking care to avoid any joists, electrical cables or water/gas pipes that may be hidden beneath the surface. Insert the rawl plugs into the holes.
- Pass the 230V 50Hz mains supply and load cable through the cable entry point on the foam gasket and then the mounting plate, ensuring the grommet is used to maintain the IP rating of the PIR sensor.
- Terminate the cable into the terminal block ensuring correct polarity is observed and that all bare conductors are sleeved (see below details on connection);

THERE ARE 2 POSSIBLE CONNECTION SCENARIOS

Standard connection – 230v Mains Installation (see diagram "G")

The factory fitted 'bridge' wire must not be removed.

Connect the 4 core mains supply cable to the block on the unit as follows:-

NEUTRAL (Blue)	N
EARTH (Green/Yellow)	
LIVE (Brown)	L

Connect the fourth core cable from the lighting load to the L¹ terminal block on the unit as follows (see connection diagram G)

SWITCHED LIVE L1

Switching DC loads or loads which use a different phase or voltage supply from the AC mains – Voltage free Installation (see diagram "H")

Remove the factory fitted 'bridge' wire.

Connect the 3 core mains supply cable to the terminal block on the unit block as follows:-

NEUTRAL (Blue)	N
EARTH (Green/Yellow)	
LIVE (Brown)	L

Connect the load in series with the load supply between L¹ and L² terminals. Please note that the function of L¹ and L² can be viewed as a simple switch controlled by the PIR sensor electronics.

4

- When wiring is complete, it is recommended that the ceiling mounting plate is fitted to the sensor body and fixed to the ceiling as follows:- (See diagram 'I' for ceiling mounting assembly method.)
- Insert fixing screws through the sensor assembly into the wall plugs and secure. Do not overtighten, if using a power screwdriver please ensure it is set to a low torque setting so as not to damage the unit. Set the unit

Diagram C Lens Mask

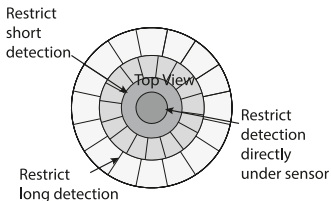

Diagram D

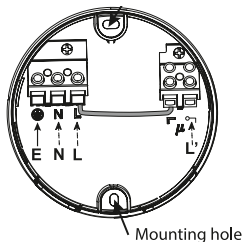

Diagram E

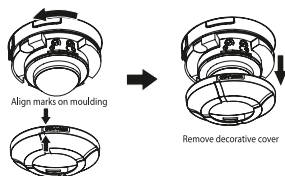

Diagram F

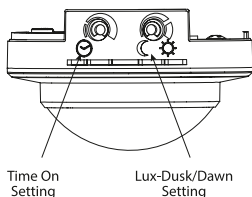

Diagram G

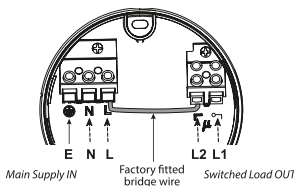
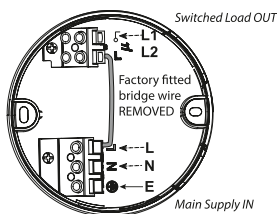

Diagram H



5

In the above illustration:

- 4 core cable may be used
- There is no external junction box
- A bridge is provided, pre-wired to bridge across live supply from AC mains to the output load via the contacts.

- The L1 L2 terminals are used to control a DC load or if the load uses a different phase or voltage supply from the AC mains in.
- Factory fitted bridge must be removed to isolate L1 & L2 terminals from AC mains in.

Diagram I

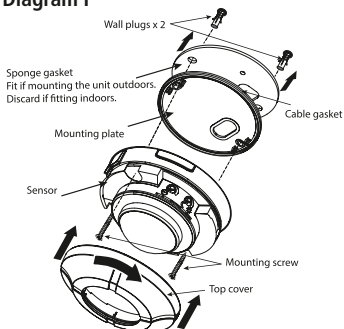

6. Setting Up

- The adjustment knobs located beneath the sensor head (see diagram "F") are factory set to "Walk Test Mode". Double check they are set as follows;
TIME – Fully anti-clockwise.
DUSK – Fully clockwise.
- Turn the power to the unit ON. The lamp will immediately illuminate as the unit goes through its "warm-up" period. After approximately 1 minute the lamp will extinguish. This indicates the unit is wired correctly and the unit is in Test Mode.
- Try to remain outside the detection area during the warm-up period.
- The unit will now operate during daytime as well as at night, illuminating the lamp for approx. 5 seconds each time. This allows testing to be carried out to establish whether the sensor is covering the required area.
- Walk around the sensor to establish the detection area.
- The sensor will detect within an approximately 9 metre diameter circle from the centre of the sensor location with a 3m ceiling. As you cross a detection "zone" the lamp will illuminate.
- Now stand still until the lamp extinguishes (this should take approx. 5 seconds). Start moving again after 2 seconds. As you cross each "zone" the lamp will illuminate.
- Repeat the above, walking at various distances and angles to the unit. This will help you to confirm the detection pattern.

7. Setting Up for Automatic Operation

- When the walk tests are complete, the unit can be adjusted for automatic operation.
- The TIME setting controls how long the unit remains illuminated following activation & after all motion ceases.
- The minimum time (fully anti-clockwise) is approx. 5 seconds, whilst the maximum time (fully clockwise) is approx. 18 minutes. Set the control to the desired setting between these limits.

- The DUSK control determines the level of darkness required for the unit to start operating. The setting is best achieved by the procedure below;
 1. Set the DUSK control knob fully anti clockwise.
 2. When the ambient light level reaches the level of darkness at which you wish the lamp to become operative (i.e. at dusk) SLOWLY rotate the control in a clockwise direction until a point is reached where the lamp illuminates.
 3. Leave the control set at this point.
- At this position the unit should become operative at approximately the same level of darkness
- Observe the operation of the unit. If the unit is starting to operate too early (i.e. when it is quite light) adjust the control slightly anti-clockwise. If the unit starts to operate too late (i.e. when it is very dark). Adjust the control slightly clockwise.
- Continue to adjust until the unit operates as desired.
- Once the unit is set up as desired, refit the top cover by aligning the arrows (See diagram "E") and twist clockwise until cover is secure.

8. Masking the Sensor Lens

- To reduce the sensor coverage, preventing detection in unwanted areas, mask the sensor lens using the lens mask sticker supplied (See diagram "C").
- For your information, the centre section of the lens covers short range detection, and the outer edge of the lens covers long range.
- Mask the sensor to suit your installation.

9. Manual Override Mode

The light can be switched ON for longer time periods by use of the Manual Override Mode. This can be activated at night by using the isolation switch.

- Switch the isolation switch twice (OFF/ON, OFF/ON) within 2 seconds.
- The unit will now illuminate continuously until dawn or until it is switched back into Detection Mode.
- To return to Detection Mode switch the isolation switch OFF and then back ON again within 1 second.

10. Troubleshooting

Problem

Solution

- Lamp stays ON all the time night and day.
Cover the PIR lens with a thick cloth. If the light turns OFF, check the detection area for heat or a reflective source.
If the light stays ON, check the wiring (See section 5. Installation and Connection).
- The PIR keeps activating for no reason at random.
Turn OFF at the isolation switch. Turn back ON again after 30 seconds. Leave for approximately 15 minutes. If the light activates, check for false activation from heat, wind or a reflective source.
- PIR sensor will not operate at all.
Check that the power is switched ON at the isolation switch. Turn OFF the power to the unit and check the wiring connections.
Check the lamp (if it's changeable).
If the lamp has failed, replace. Ensure the lamp is seated correctly in the lamp-holder.
Note: the unit will not detect through glass. (e.g. in a glazed porch).
- PIR sensor will not operate at night.
The level of ambient light in the area may be too bright to allow operation at the current DUSK setting.
During the hours of darkness, adjust the DUSK control slowly clockwise until the lamp illuminates.

- PIR activates during the daytime. Adjust the DUSK control setting anti-clockwise to lower the level of ambient light required for activation.
- PIR coverage is poor/sporadic The PIR may be poorly located (See section 4. Selecting a location) and re-locate the unit.
- Detection range varies from day to day. The PIR detectors are influenced by climatic conditions. The colder the ambient temperature, the more effective the sensor will be.
You may need to make seasonal adjustments to the detector head position to ensure trouble-free operation all year round.

3 Year Guarantee

In the unlikely event of this product becoming faulty due to defective material or manufacture within 3 years of the date of purchase, please return it to your supplier in the first year with proof of purchase and it will be replaced free of charge. For years 2 and 3 or any difficulty in the first year, telephone the helpline on 020 8450 0515.

Note: A proof of purchase is required in all cases. For all eligible replacements (where agreed by Timeguard) the customer is responsible for all shipping/postage charges outside of the UK. All shipping costs are to be paid in advance before a replacement is sent.



If you experience problems, do not immediately
return the unit to the store.

Telephone the Timeguard Customer Helpline;

HELPLINE

020 8450 0515

or email helpline@timeguard.com

Qualified Customer Support Co-ordinators will be on-line
to assist in resolving your query.



A **theben** Group Company

For a product brochure please contact:

Timeguard Limited.

Victory Park, 400 Edgware Road,

London NW2 6ND

Sales Office: 020 8452 1112

or email csc@timeguard.com

www.timeguard.com