

Type B Outstation

The EVCS Type B Outstation is designed to fully comply with BS5839 for use as a Fire Telephone system, Disabled Refuge Call system or as a combined system when both Fire Telephones and Disabled Refuge Points are required.

The Type B Outstation is designed to be versatile, compact and easy to use Refuge Call Point. This unit can be surface mounted using a simple to install bezel.

When choosing the Outstation Type for use with an EVCS we recommend reading Section 11 of BS5839-9:2003 which deals with Outstation Types. Type B Outstations can only be used where the background noise is below 40dBA (therefore there can be no sounder or Voice Alarm coverage in the area).



TECHNICAL SPECIFICATION			
Code:	EVCS-HSBG	EVCS-HSB	EVCS-HSFSS
Description	Surface Outstation Type B		
Standards	EMC: EN55103-1 & EN55103-2 LVD: EN60950 Product Family BS5839 Pt9 & BS9999 & EN60118-4		
Outstation Cables:			
Glands	20 mm		
Cores	2 core 1 mm or 1.5 mm		
Distance	500 m		
Indications & Controls:			
Status LEDs	2 off red (flashes location lights, solid in use)		
Call	Press to call button		
Cancel	Press to cancel button		
Physical:			
Construction	Zintec, Powder Coated		
Colour Option	Green	Red	Stainless Steel
Dimensions (H x W x D)	135 mm x 135 mm x 45 mm		
Weight	1105g		

KEY FEATURES

- Compact design
- Available in Red, Green and Stainless Steel finishes
- Loop output for hearing impaired users
- Tactile braille signage to assist partially sighted people to easily operate Refuge Point
- Full duplex operation, allowing 2 way voice communication
- High volume ringer
- Status LED
- Flush bezel available
- Versatility, the unit can be used on all the EVCS systems

HANDS FREE COMMUNICATIONS

Push button dialling to Compact- 9 and Network 8 system

Echo cancellation

Noise reduction

Induction loop output for hearing impaired users

Push button cancel

Braille Signage

ELECTRICAL SPECIFICATION

Fully monitored connections	DC open, DC Short and Earth Fault
-----------------------------	-----------------------------------

STATUS LED

Flashing for line location

Continuously lit to indicate call confirmation active

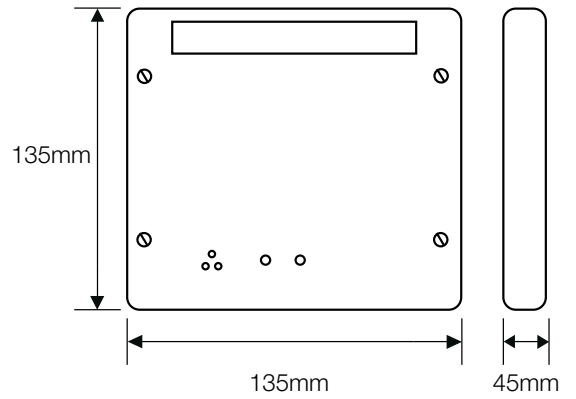

ORDER CODES

Model:	Description:
EVCS-HSB	Surface Outstation Type B,Red
EVCS-HSBG	Surface Outstation Type B,Green
EVCS-HSFSS	Surface Outstation Type B,Stainless Steel
EVCS-VCFHB	Flush Mounting Bezel Type B,Stainless Steel

Honeywell

Tel: +44 (0) 116 246 2000

Fax: +44 (0) 116 246 2300

Email: hlsuksalesupport@honeywell.com

140 Waterside Road

Hamilton Industrial Park

Leicester

LE5 1TN

October 2015
© 2015 Honeywell International Inc.

Honeywell