

5000 Series: Model 5012

Infra-Red Transit Heat Sensor



The 5000 Series is an early warning infra-red transit heat sensor, which can trigger at temperatures as low as 100°C, when monitoring materials being transported on conveyor systems, before they have reached the ember or flame condition.

Its unique eight detector enhanced Infra-red monitoring has been created to detect black heat. Black body emissions occur for all material, the sensor is designed to detect a change in these emissions even at relatively low temperatures, when the material moves through its field of view.

Air purging from a compressed air feed is used to maintain a positive air pressure in the sensor enclosure, an air knife ensures the prevention of dust settling on the sensor window. The air supply is monitored by a pressure switch which on air failure is signalled as a fault status.

The 5020 controller is directly connected to the sensor. A series of user programmable DIL switches allows option selection including detector sensitivity settings, auto/manual reset sequence selection and single / coincidence voting from the four individual internal detection channels for the alarm trip and shutdown outputs.

The sensor air pressure and signal cable connections are fault monitored and fail safe. The controller incorporates an aux. fault input & common fault output contact.

Features

Detection of hazards at temperatures below flame point including both embers and buried hot spots.

Air purged system for dusty environments with air pressure monitoring.

Four Channels of Detectors (two detectors per channel) for Maximum reliability.

Multi-Facet lensing provides wide uniform coverage

Single / Coincidence voting output

Timed auto reset / coincidence analyser circuit

Tuned response — solar blind

Voting Logic & Latching options

Alarm & Trip Functions

Fault Monitored, with Test & Reset push Buttons

Field Programmable

Local Indicators

Applications

Conveyors

Escalators

Drying Lines

Sorting Machines

Food Processing

Baggage Handling

Production Lines

Warehouse Robots

Waste Recycling Conveyors

5000 Series: Model 5012

Infra-Red Transit Heat Sensor

5020 Controller

Includes LED indication of the Four detector channels; along with LED indication and relay outputs for Alarm, Trip and Fault.

The control module is easily de-mountable and allows installation of the housing and site cables prior to fittment of the module.

The controller can be provided in an optional outer control panel together with power supplies, battery chargers, DIN rail terminals, etc. as required.

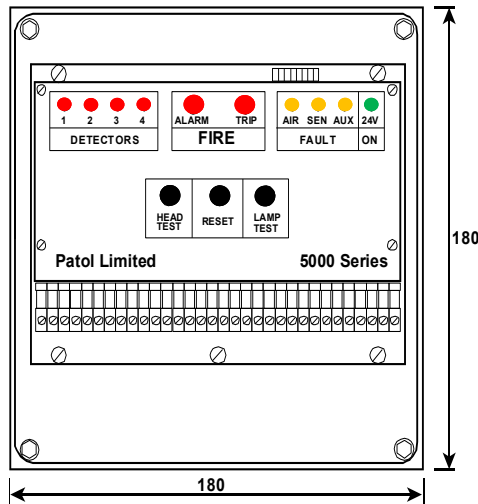

TYPICAL SYSTEM

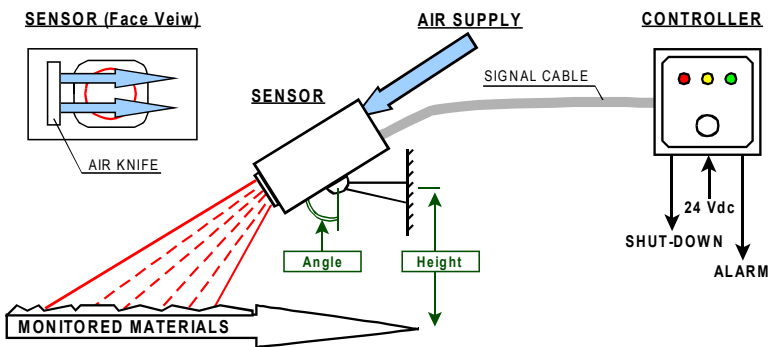

The sensor is located above or beside the materials transit path (conveyor, roadway, etc.) by means of the adjustable mounting bracket and aligned such that the monitored hazard passes through the sensor's field of view. The distance and angle of the sensor determine the width of the monitored path.

Typically conveyor widths of 1.6 to 4.2 m can be monitored with a sensor mounted 1.0 to 1.5 m above the conveyor at an angle of 0° to 55° (see separate datasheet).

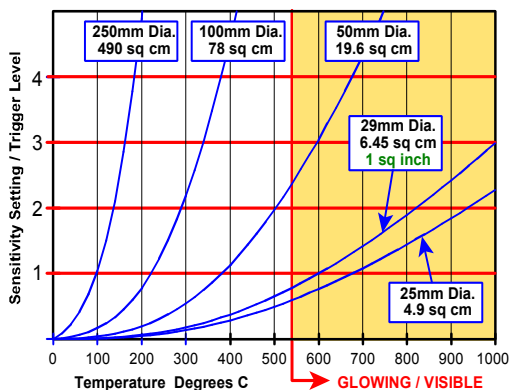

The chart (left) indicates the correlation between the temperature and size of 'hot spot' anomalies for a typical installation to produce one or more detector channel activations at various trigger level settings.

Exact response is dependant on the emissivity factor of the monitored material, sensor orientation and target speed.

Specification

Detectors:	8 off-Interlaced lensing configured as four channels.
Spectral Filter:	5 - 14 μ m (wide band)
Sensitivity:	10 - 40 μ W
Transit Speed:	0.5 to 6 m/s
Sensor Head:	2.9Kg
Material:	Stainless Steel
IP Rating:	IP67
Controller:	5020
Material:	Polycarbonate 1Kg (IP 66)
Supply Voltage:	20-30 Vdc
Supply Current:	35 mA Quiescent 70 mA Max / Full Alarm
Temperature:	-20°C to +70°C
Outputs:	Alarm Contact - 1 Pole C/O Trip Contact - 1 Pole C/O Fault Contact - 1 Pole C/O
Rating:	- 30 Vdc - 500 mA
Auxiliary Input:	PSU / Charger etc.
Purge Air:	Input Fitting: 1/4 inch NPT Pressure: 0.7 Bar (10 psi) Delivery: 1.9 litres/sec (4 cubic feet/min)

Ordering Information

Description	Part Number
5012: Stainless Steel, Controller 5020,	710-006
10m cable, Mounting Bracket	
Sensor 5012 (without Controller)	710-015
Controller 5020	710-020
Specials	Reference Drawing
Single 5020 Control Panel with PSU /	11152
Charger, Reset & space for Batteries	

PATOL
FIRE DETECTION SOLUTIONS