

# DC115

## OVERHEAD CONT. 5 WIRE

### Industrial Contact

---

The DC115/DC118 are designed to be installed in commercial and industrial environments where a rugged sealed unit is required. It is ideal for metal doors, overhead doors, fences and gates. Each model features a high strength extruded aluminium housing and is completely encapsulated in an exclusive polyurethane potting compound.

### Comprehensive Range

---

The range features wide gap distances and several models to meet any application need. Armoured cable is available.

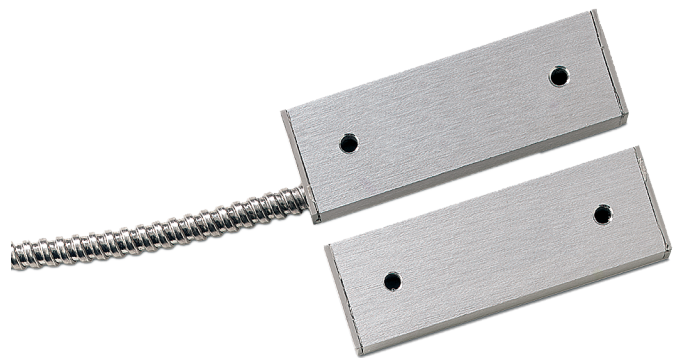

### Details

---

- Mounting brackets available for gates, garage doors, freezers
- Rugged construction for long life
- Convenient surface mounting
- 2 m armoured cable
- Tamper loop provided
- DC115 is polarity-sensitive with reference to magnet direction

# DC115

## OVERHEAD CONT. 5 WIRE

### Technical specifications

---

#### General

Application type	Surface Mount
Contact type	CO
Connectivity	5 wires, 2 m

#### Wired/wireless

Wired-wireless	Wired
----------------	-------

#### Physical

Material	Anodised aluminium finish
Dimensions magnet	76 x 12 x 25 mm
Dimensions contact / sensor	76 x 12 x 25 mm
Operating gap	9-62 mm

#### Standards & regulation

EN50131 grade	Grade 2
---------------	---------

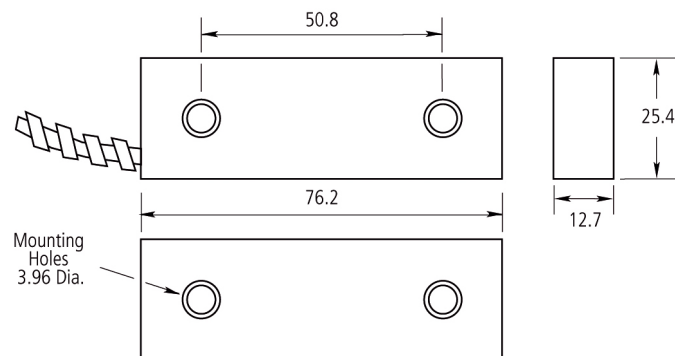

As a company of innovation, UTC Fire & Security reserves the right to change product specifications without notice. For the latest product specifications, visit UTC Fire & Security online or contact your sales representative.

30 April 2019 - 11:30