



DC102

DC102 ARITECH (FORMERLY 1085T-N4)

Easy Installation

The DC102-series are ideal for residential and commercial applications where terminal connections are preferred. The unit features positive clamping terminals with anti-rotation lugs and captured screws with combination heads. These features allow for easy, quick installations.

Comprehensive Range

The range includes wide gap, SPDT and biased versions for higher security. This makes it one of the most popular contacts available in the industry today.

Durability and dependability

These high performance magnetic contacts have been designed to facilitate installation and ensure durability and dependability. Most are conservatively rated at 10,000,000 cycles, guaranteeing a long life. Every reed connection is hand soldered and each magnetic contact is tested before they leave the factory.

High quality components and materials

Reed legs are plated with rhodium or ruthenium, and hermetically sealed in dry nitrogen. This offers superior protection against sticking and provides a moisture free environment therefore preventing corrosion.



Details

- Ideal for residential and commercial
- Convenient surface mounting
- Versions with built-in resistors available

DC102

DC102 ARITECH (FORMERLY 1085T-N4)

Technical specifications

General

Application type	Surface Mount
Contact type	NC
Connectivity	Screw

Wired/wireless

Wired-wireless	Wired
----------------	-------

Physical

Physical dimensions	63 x 12 x 19 mm
Colour	White
Operating gap	18 mm

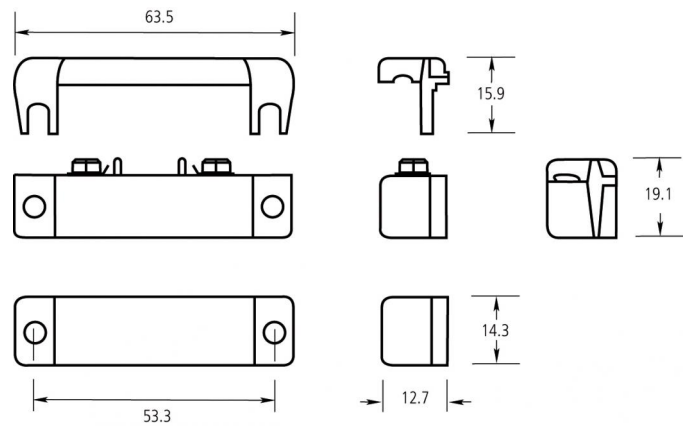

As a company of innovation, UTC Fire & Security reserves the right to change product specifications without notice. For the latest product specifications, visit UTC Fire & Security online or contact your sales representative.