

Category C. Loop Powered VADs



Product overview

Product Type	Visual Alarm Device
Part No.	55000-742 (Red body, white flash 8.5m) 55000-745 (White body, white flash 8.5m)
Digital Communication Protocol	CoreProtocol®, Discovery & XP95 compatible

Product information

The VAD has been developed as a primary or supplementary alarm device for use in situations where there is a risk that sounders will not be heard. This occurs, for example, where there is high background noise e.g. in a workshop or a machine room.

It might also be required where deaf or hearing impaired persons may be present.

- Uses high intensity LED (white flash only)
- EN 54-23 Compliant Category C. VAD
- Coverage C-3-8.5
- Automatic LED check when VAD activated
- Flash rate 0.5Hz
- Fault signal if LED check failed
- Locking mechanism (grub screw)
- Wide angle of visibility
- Synchronised with the Apollo Protocol

Technical data

Coverage class	C-3-8.5
Flash rate (white flash only)	0.5Hz
Supply voltage (Vmin–Vmax)	17-28V DC (polarity sensitive)
Digital communication protocol	CoreProtocol, Discovery & XP95 compatible
Quiescent	150µA
Power-up surge current	1.5mA
Alarm current (LED on)	9.4mA
Operating temperature*	-10°C to 55°C
Humidity	0% to 95% RH (no condensation or icing)
Vibration, impact & shock	EN 54-23
IP Rating	IP54
(Tested and approved by TRaC Global Limited testing laboratory)	(when used with 45681-210 or 45681-284 Mounting Base) IP55 (when using the Deckhead Mounting Box 45681-217)
Standards & approvals	EN 54-23, CPR & LPCB
Dimensions	100mm diameter x 50mm height (58mm height with XPERT 7 Mounting Base)
Weight	105g

* Tested by Apollo Fire Detectors Limited to -40°C to 70°C

Application

The Loop Powered Addressable Visual Alarm Device is a local-area VAD designed for indoor use.

The VAD can be connected to systems with Soteria®, Discovery or XP95 devices on the loop.

The Loop Powered VAD can be fitted to any XPERT 7 or XPERT 8 Mounting Base.

When fitted to an Ancillary Base Sounder (part no. 45681-276), the sounder activation will be controlled by the VAD.

When fitted to an Integrated Base Sounder the devices can be controlled separately via their individual address.

Electrical Considerations

The VAD is loop powered and requires no external power supply. It operates at 17–28V DC.

Figure 1 Category C. Loop Powered VAD with XPERT 7 Mounting Base coverage area and mounting instructions

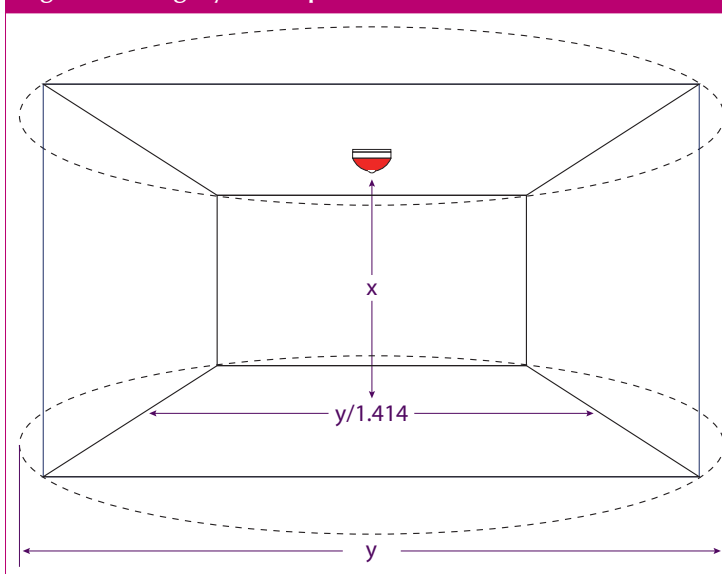

X - The maximum height in metres at which the VAD may be mounted.

Y - The diameter in metres of the cylindrical volume covered when the device is mounted to the ceiling at a height of 3m.

55000-742/55000-745 (C-3-8.5) - Coverage Cylindrical Volume of $\pi \times (8.5 \div 2)^2 \times 3 = 170\text{m}^3$

Table 1 Protocol bit usage

Output Bit Settings			VAD/Sounder Action
2*	1	0	
0	0	0	VAD off, ancillary sounder off (if connected)
0	0	1	VAD on, ancillary sounder on (if connected)
0	1	0	VAD on, ancillary sounder off (if connected)
0	1	1	VAD on, ancillary sounder on (if connected)

* Output bit 2 is not used

Loop Loading

Up to 12 VADs may be fitted between standard XP95 isolators (part no. 55000-700/710/720) or isolating mounting bases (part no. 45681-284, which replaced part no. 45681-321).

In order to determine the exact number in a loop please use the 'Loop Calculator' available as a free download on the Apollo website: www.apollo-fire.co.uk

Addressing

The Loop Powered VAD must be assigned an address by coding the XPERT card in the usual way.

Protocol Compatibility

The VAD will operate with compatible Apollo control equipment using the digital XP95, Discovery or CoreProtocol. The features of the VAD are available only when the VAD is connected to a fire control panel with the appropriate software.

Mechanical Construction

The case of the VAD is made of white or red self extinguishing polycarbonate with stainless steel contacts.

EMC Directive 2004/108/EC

The VAD complies with the essential requirements of the EMC Directive 2004/108/EC, provided that it is used as described in this datasheet.

A copy of the Declaration of Conformity is available from the Apollo website: www.apollo-fire.co.uk

Conformity of the VAD with the EMC Directive, does not confer compliance with the directive on any apparatus or systems connected to it.

Construction Products Regulation 305/2011

The VAD complies with the essential requirements of the Construction Products Regulation 305/2011.

A copy of the Declaration of Performance is available from the Apollo website: www.apollo-fire.co.uk

Category C. Loop Powered VADs

Figure 2 Category C. Loop Powered VAD with XPERT 7 Mounting Base dimensional drawing (C-3-8.5 coverage area VAD)

