

Description:
 Resettable Call Point Green
 (Access Control)

LED:
 LED lens cover diffraction

Materials:
 ABS Case either with a
 Transparent Polycarbonate Cover
 or Film protected Glass Cover with
 Test Key

Resistor:
 Inbuilt 470 or 680 Ohm R Series

Voltage Range:
 18 - 30v DC
 2 in 2 out terminal block

Maximum Current - 50mA
Contact Resistance - <30Ω
Resistive Power Rating - 0.25w

Temperature Range:
 -40°C to +50°C

Colours:
 Wide range available
 Fixing Screws Provided

Units comply to BS5839 Part 2, 1983

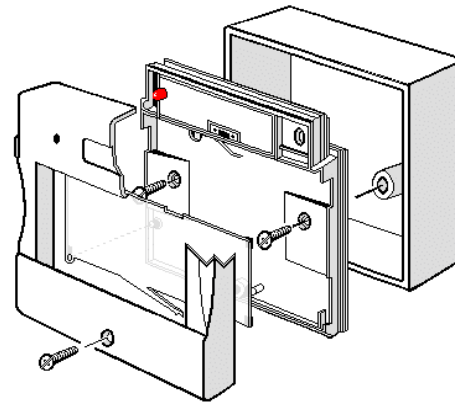
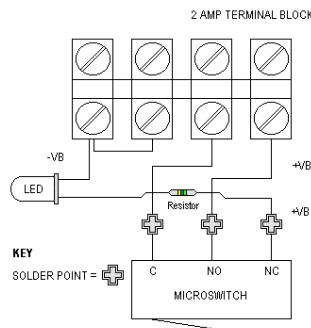

KNIGHT

FIRE & SECURITY PRODUCTS LTD

<mailto:info@knightfireandsecurity.com>

Unit 84 Seawall Road Ind. Estate
 Cardiff UK CF24 5TH

Tel: 0 (00 44) 29 20 48 81 29

Fax: 0 (00 44) 29 20 48 91 32

Drawing No: CP15-W15

Drawn: Chris Moorman

Date: 04/09/09

All dimension in mm
 Do not scale



© Knight Fire & Security Products Ltd
 All cases of ™ Infringement will be pursued.