

# TIMEGUARD®

## LED Half Carriage Lantern

Model: CLLEDH42B – Black

Model: CLLEDH43WH – White



Installation & Operating Instructions

# 1. General Information

These instructions should be read carefully and retained for further reference and maintenance.

## 2. Safety

- Before installation or maintenance, ensure the mains supply to the luminaire is switched off and the circuit supply fuses are removed or the circuit breaker turned off.
- It is recommended that a qualified electrician is consulted or used for the installation of this luminaire and install in accordance with the current IEE wiring and Building Regulations.
- Check that the total load on the circuit including when this luminaire is fitted does not exceed the rating of the circuit cable, fuse or circuit breaker.

## 3. Technical Specifications

- 230V AC 50 Hz
- This Luminaire is of class II construction and must not be earthed
- Lamp Type Supplied: 4W LED
- Energy Efficiency: Class A
- Energy Usage: 4kWH/1000H (Lamp Supplied)
- Lumen Output: 320-335lm
- Colour Temperature: Warm White 2900 – 3200K
- Operating Temperature: -10°C to 40°
- IP44 Rated suitable for limited external applications
- Beam angle: 120°
- Lamp Rating: 60W halogen (max.)  
18W compact fluorescent (max.)  
5W LED (max.)
- CE Compliant: Yes

## 4. Installation

1. **IMPORTANT** Switch off the electricity at the fuse box by removing the relevant fuse or switching off the circuit breaker before proceeding with the installation.
2. An isolating switch should be installed to switch the power to the unit on and off. This is for maintenance purposes.
3. Remove the front housing machine threaded bolts from the wall mount plate using the hexagonal Allen key supplied, see diagram A.

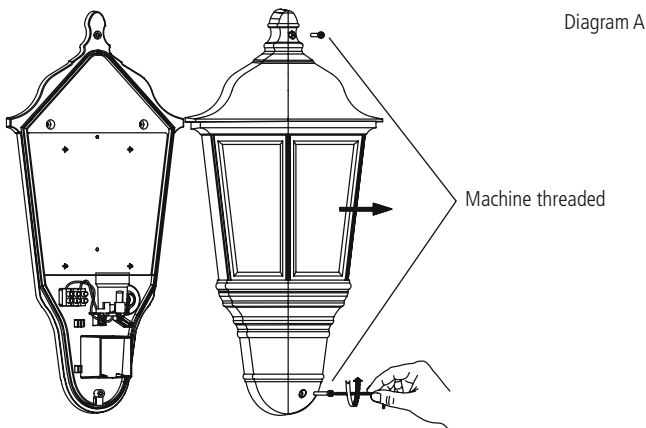

2

4. Using both hands gently lift the front housing from the wall mount plate with each hand at the top and bottom lengths of the housing. Once removed place the front housing in a safe area to reapply later.
5. Using the back plate as a template mark the position for the holes. Note the back plate must be mounted in the correct orientation as shown in diagram B.
6. Drill the wall using a 6mm Ø masonry drill bit making sure not to infringe or compromise any gas, water pipes or cables. Insert the supplied rawl plugs into the previously drilled holes.
7. Pierce the pre-installed rubber grommet and pass through the 230V AC 50Hz mains supply cable. Ensuring the IP rating of the fitting is maintained (Silicon sealant may be used).

8. Secure the back plate to the wall using the screws provided.

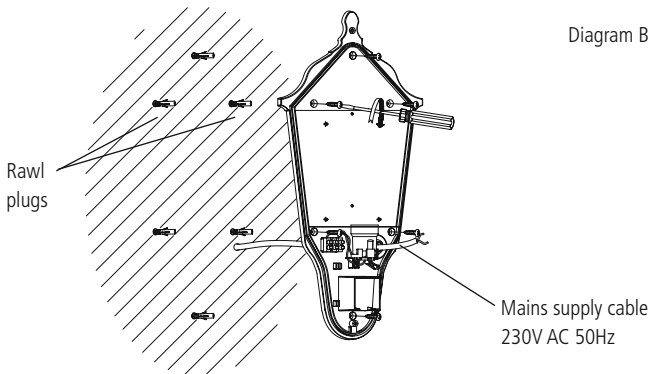

9. Use the cable clamp next to the grommet to hold the supply cable securely in place.

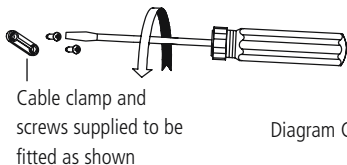
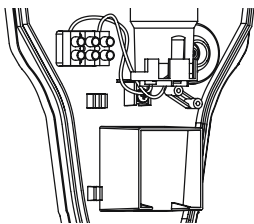

10. Connect the 230V AC 50Hz mains cable to the terminal block ensuring that all bare conductors are sleeved and that correct polarity is observed. For wiring please refer to section 5 Connection Diagram.
11. Decide if the plain or frost panel is required for the installation, there are two screws that hold the panel to the front housing located on the top and bottom centre of the panel. Please note the front housing will have the clear panel attached by default.

12. If the frost finish is required unscrew the two supporting screws pre-applied from the front housing; ensure the front housing is lying down when doing this.
13. Unclip the panel by gently applying pressure and push inwards from the outer side of the panel until it clips away from the front housing.
14. Align the frosted panel screw holes to the two moulded holes fixtures on the front housing which are pre-threaded, ensure the panel is clipped in firmly.
15. Apply the screws to the frosted panel used to remove the clear panel.
16. Insert the supplied LED lamp into the lamp holder as shown in diagram D and twist clockwise until secured.

Diagram D

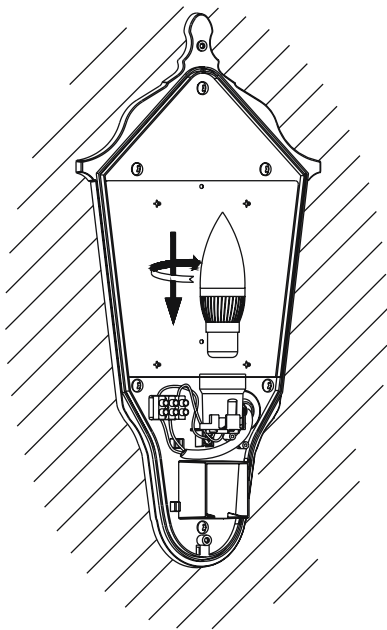

- Align the front housing with the wall mount plate and clip the two parts in place
- Use the two machine threaded bolts to screw the two parts together using the Allen key supplied. Note that the longer security screw must be fixed to the bottom of the lantern and the shorter screw fixed at the top half, see diagram E for reference.

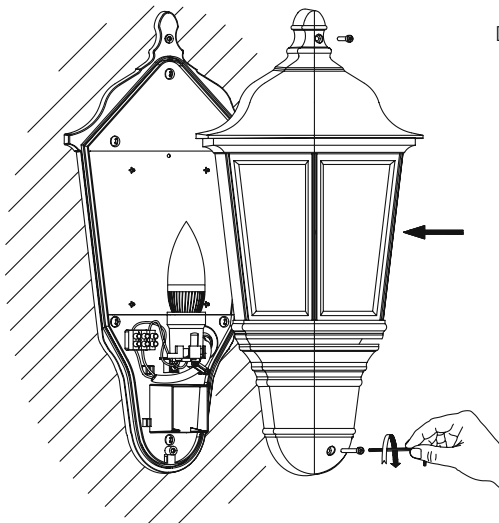
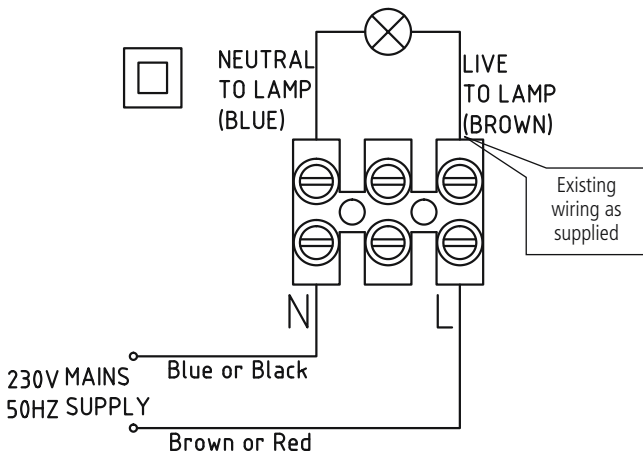

Diagram E

- Once the bolts are held tightly in place the unit will be ready for operation (see section 6 operating and testing).

## 5. Connection Diagram



## 6

## 6. Operation and testing:

- Turn the power to the unit on, and the unit will illuminate.

## 3 Year Guarantee

In the unlikely event of this product becoming faulty due to defective material or manufacture within 3 years of the date of purchase, please return it to your supplier in the first year with proof of purchase and it will be replaced free of charge.

For years 2 and 3 or any difficulty in the first year, telephone the helpline on 020 8450 0515.

Note: A proof of purchase is required in all cases. For all eligible replacements (where agreed by Timeguard) the customer is responsible for all shipping/postage charges outside of the UK. All shipping costs are to be paid in advance before a replacement is sent.

If you experience problems, do not immediately return the unit to the store. Telephone the Timeguard Customer Helpline;

HELPLINE

**020 8450 0515**

or email [helpline@timeguard.com](mailto:helpline@timeguard.com)

Qualified Customer Support Co-ordinators will be on-line to assist in resolving your query.



A **theben** Group Company

For a product brochure please contact:

**Timeguard Limited.**

Victory Park, 400 Edgware Road,

London NW2 6ND

Sales Office: 020 8452 1112

or email [csc@timeguard.com](mailto:csc@timeguard.com)

**[www.timeguard.com](http://www.timeguard.com)**