

LDM-519-SEN-N

LHD Interface for Analogue Cable



The SEN-N Controller is designed to monitor a zonal length of resettable (Analogue) Linear Heat detection Cable (LHDC) for both an elevated temperature (Fire) condition, and Fault Status (Open & Short Circuit).

The Controller offers two adjustable levels of alarm (A1 & A2), one of which may be optionally employed as a "Pre Alarm". The LHDC is also monitored for fault conditions (open and short circuit).

LHDC is of coaxial construction and is used in conjunction with an End Of Line (EOL) terminator. The Controller provides early warning of hot spots and fire conditions on short sections of the overall LHDC zone length. Maximum LHDC zone length for Analogue cable is 500m.

The modular form of the unit enables it to be provided in a variety of bespoke housings and readily integrated into special control panels.

Features

Two level Alarm set points

Adjustable Alarm set point

LED Indication of Fire, Fault and Supply Status

Wide dc supply operation 20Vdc to 60Vdc
(positive earthed)

Fault Monitoring for open & short circuits

Selectable Latching / Auto reset operation

VFC relay outputs for Fire & Fault conditions

Applications

Cable Tunnels, Ducts & Mezzanines

Escalators & Moving Walkways

Petro-Chemical Floating and Fixed Roof Tanks.

Refrigerated Stores & Cold Rooms

Ceiling Voids & Attic Spaces

Conveyor, Bearing Protection

Car Parks, Open Storage Areas

Warehousing, Racking Protection

LDM-519-SEN-N

LHD Interface for Analogue Cable

The alarm relay outputs can be operated in two modes.

Mode 1; where a single alarm level operates both relay outputs. This is achieved by adjusting the A2 set-point to less than that for A1. Thus both A1 & A2 trip simultaneously - **At the A1 set point.**

Mode 2 with pre alarm; where a two stage alarm operates. This may be achieved by using A1 for Pre-Alarm and A2 for Alarm.

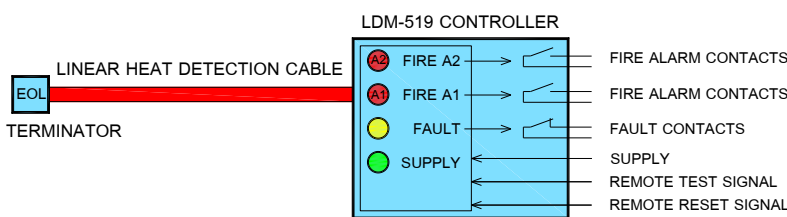

Specifications

Dimensions:	(WDH) 220mm x 120mm x 76mm
Weight:	0.85Kg
IP Rating:	IP66
Material:	Polycarbonate
Supply Voltage:	20Vdc to 60Vdc
Supply Current:	Quiescent <18mA
	Max (Alarm) <60mA
Relay Contacts:	1A @ 24Vdc/120Vac
	Fire Alarm A2 1x1 pole change over
	Fire Alarm A1 1x1 pole change over
	Fault 1x1 pole change over

Connections

LDM-519 Module terminals showing typical external connections.

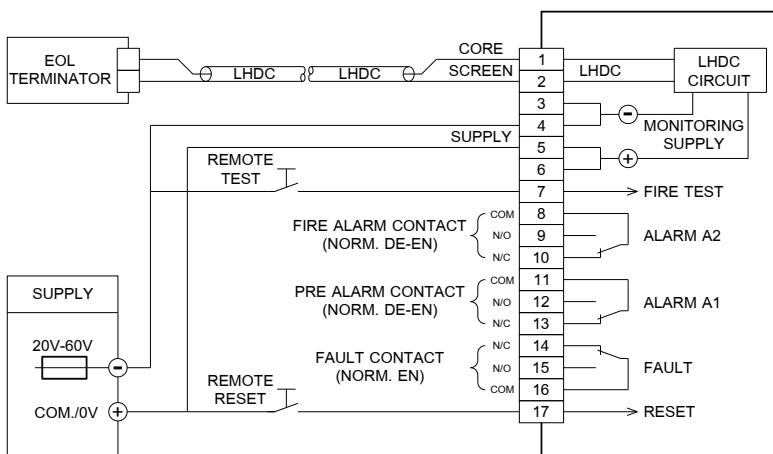

Ordering Information

Description	Part Number
LDM-519-SEN-N	700-305

Used with the following Analogue cables:

Red PVC	700-001
Red PVC S.S*	700-005
Black Nylon	700-003
Black Nylon S.S*	700-004

* Stainless Steel Braid